



# Creative Engineers, Inc.

CUSTOMER DRIVEN SOLUTIONS  
New Freedom, PA | Greenville, SC  
15425 Elm Drive, New Freedom PA 17349  
(717) 235-5469

[www.creativeengineers.com](http://www.creativeengineers.com)  
[info@creativeengineers.com](mailto:info@creativeengineers.com)

## AC EM PUMPS

Alternating Current  
Electromagnetic Conduction Pumps

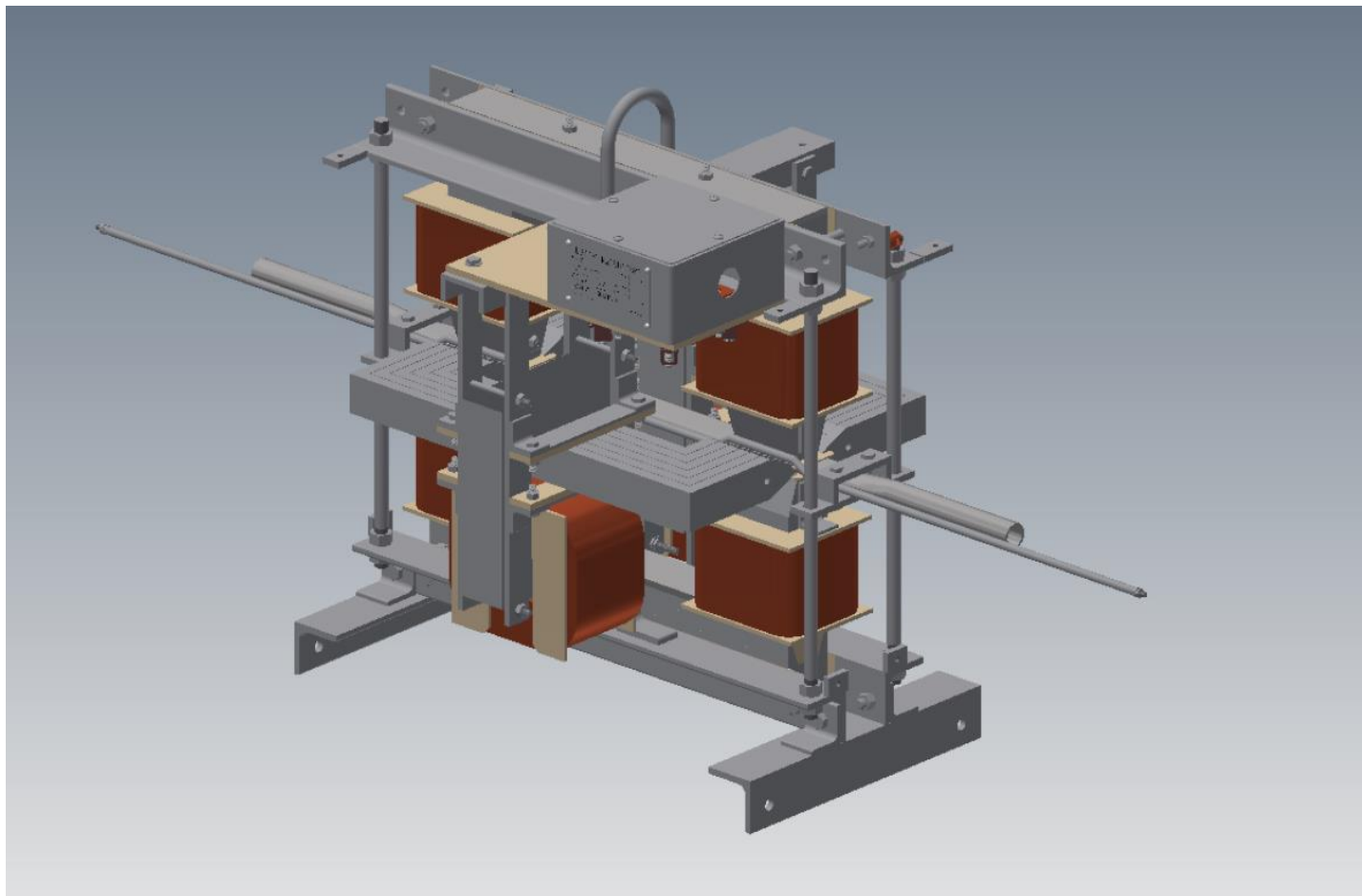

# FEATURES

1. Continuous operation at liquid metal temperatures up to 1,600°F/871°C.
2. No moving parts + no seals + no packing glands = no leaks!
3. Flow control from 10 to 100 % of capacity with no throttling valves.
4. Full reversible flow can be achieved within minutes.
5. Low maintenance – reliable for 20+ years.
6. Operable in radiation fields.
7. Proven performance since 1950.

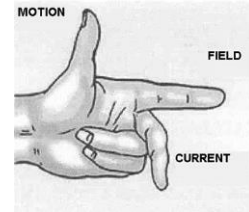

# PRINCIPLES OF OPERATION

Creative Engineers, Inc.'s AC Electromagnetic Conduction Pump operates on the principle of Fleming's Left Hand Motor Rule. This describes the direction of a force produced on a conductor by a current and a magnetic flux. That principle is illustrated in the diagrams to the right.

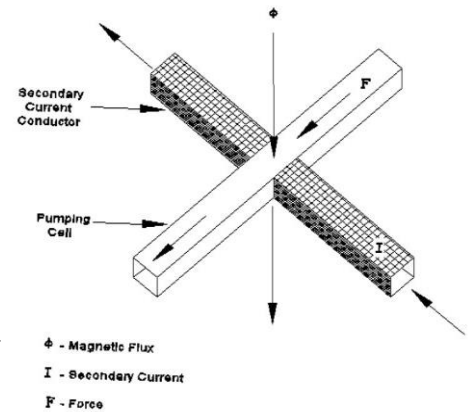

In a conduction-type electromagnetic pump, the liquid metal is the conductor of electricity. When current passes through the pump section (perpendicular to the magnetic field), a force is produced within the liquid metal inside the pumping section that is at right angles to the current and magnetic field.

The diagram below shows how the current and flux are produced in a CEI two-stage electromagnetic pump.

Two current transformers, connected additively, supply the current in the secondary conductor (bus bars). The current flows through the pumping section wall, horizontally across the liquid metal, and out the other pipe wall. This forms a continuous current path which flows across one pumping section and returns to the other pumping section. The bus bars are attached to the pumping section using high-temperature brazing compounds.

The magnetic flux in the pumping section is produced by coils on each leg of the two U-shaped laminated magnetic iron cores. The cores are positioned so that the two flattened portions of the pumping section are in the air gaps. The flux flows vertically downward through one pumping section and returns through the other.

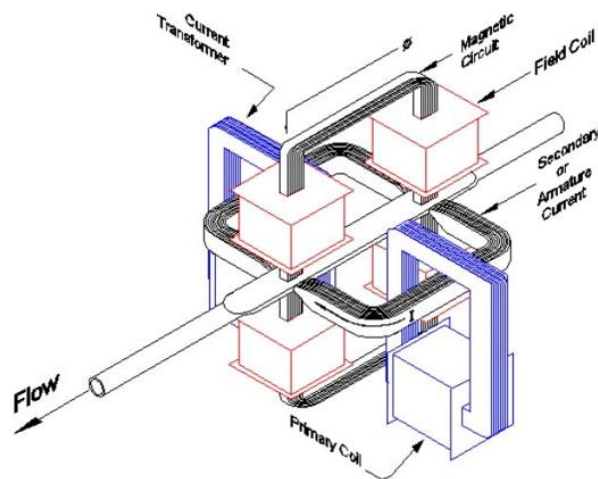

**TWO STAGE ELECTROMAGNETIC PUMP**

The flow rate of all CEI AC conduction-type EM pumps is positively controlled from 10 to 100% by a variable transformer. A capacitor is used for power factor conversion. The tables below show the dimensions and weight of the variable transformers and capacitors.

| EM Pump Style | Capacitor(s)        | Powerstat (Variac) Input                    | Powerstat (Variac) Output | Capacitor Dimensions (in x in x in) | Capacitor Weight (lb) |
|---------------|---------------------|---|---------------------------|-------------------------------------|-----------------------|
| EMP-2-1       | 2 @ 240 V, 7.5 KVAR | 240 VAC, 1-Phase, 2-Wire + Ground, 50/60 Hz | 7.8 KVAR, 28 A            | 10 x 8 x 11                         | 56                    |
| EMP-2-2       | 1 @ 240 V, 10 KVAR  | 240 VAC, 1-Phase, 2-Wire + Ground, 50/60 Hz | 7.8 KVAR, 28 A            | 12 x 10 x 11                        | 62                    |
| EMP-2-3       | 1 @ 240 V, 5 KVAR   | 240 VAC, 1-Phase, 2-Wire + Ground, 50/60 Hz | 7.8 KVAR, 28 A            | 12 x 6 x 11                         | 37                    |
| EMP-2-4       | 1 @ 240 V, 2.5 KVAR | 240 VAC, 1-Phase, 2-Wire + Ground, 50/60 Hz | 7.8 KVAR, 28 A            | 8 x 6 x 11                          | 28                    |
| EMP-2-5       | 1 @ 240 V, 10 KVAR  | 240 VAC, 1-Phase, 2-Wire + Ground, 50/60 Hz | 7.8 KVAR, 28 A            | 12 x 10 x 11                        | 62                    |
| EMP-2-6       | 1 @ 240 V, 7.5 KVAR | 240 VAC, 1-Phase, 2-Wire + Ground, 50/60 Hz | 7.8 KVAR, 28 A            | 10 x 8 x 11                         | 56                    |

### POWER SUPPLY REQUIREMENTS

Our standard pumps require an electrical supply of 240 Volts AC, single phase, 60 Hertz.

### FLOW DIRECTION

Flow is easily reversed by changing the direction of the magnetic field. This can be accomplished by including switching equipment during installation, or (for our Style EMP-2-3, EMP-2-4, EMP-2-5, and EMP-2-6 pumps) by changing two connections in the terminal box.

### WIRING

A wiring diagram on the right shows the connection to the pump terminal and interconnections to the required auxiliary equipment. CEI routinely provides all necessary auxiliary equipment for pump installation and operation, including a capacitor to correct the power factor, and an auto-transformer to vary the power.

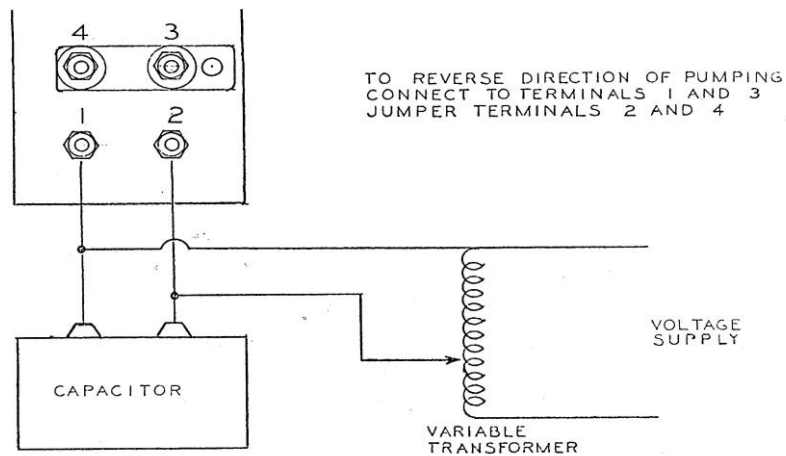

WIRING DIAGRAM

## APPLICATIONS

The performance curves shown here were obtained with potassium-sodium alloy (NaK). For fluid temperatures above 900°F (482°C), pump performance with sodium, potassium, and NaK will all be similar to these graphs. CEI pumps can also be used with rubidium, lithium, and a variety of alkali metal-containing alloys and other liquid metals.

The pumps will operate at any point on or below the maximum curves. The pumps are pressure devices; with a fixed applied voltage flow will be established according to the pressure drop in the system external to the pump.

The performance of any given pump will vary somewhat with the type of fluid, temperature, and materials of construction. Effective pumping in an AC conduction EM pump requires that the liquid metal wet the pump tube. It is best to select a pump with a maximum performance curve above the expected normal operating point, or to specify required performance and details of the application so that CEI can recommend the appropriate pump.

The process temperature is dependent on the materials of construction and the fluid being pumped. Odd numbered pumps (Styles EMP-2-1, EMP-2-3, and EMP-2-5) are least affected by temperature. A slight improvement in operation will be noted up to approximately 1,000°F (540°C), after which a slight reduction in performance will result (vs. even numbered pumps). A sharp reduction in performance will occur in the even numbered pumps (Styles EMP-2-2, EMP-2-4, and EMP-2-6) below 800°F (427°C) due to the magnetic field of the nickel used to achieve higher temperature limits.

Our standard EM pumps are fabricated primarily from 316 stainless steel. Other tube materials may be used, provided they are non-magnetic, can be brazed, and are compatible with the fluid being pumped.

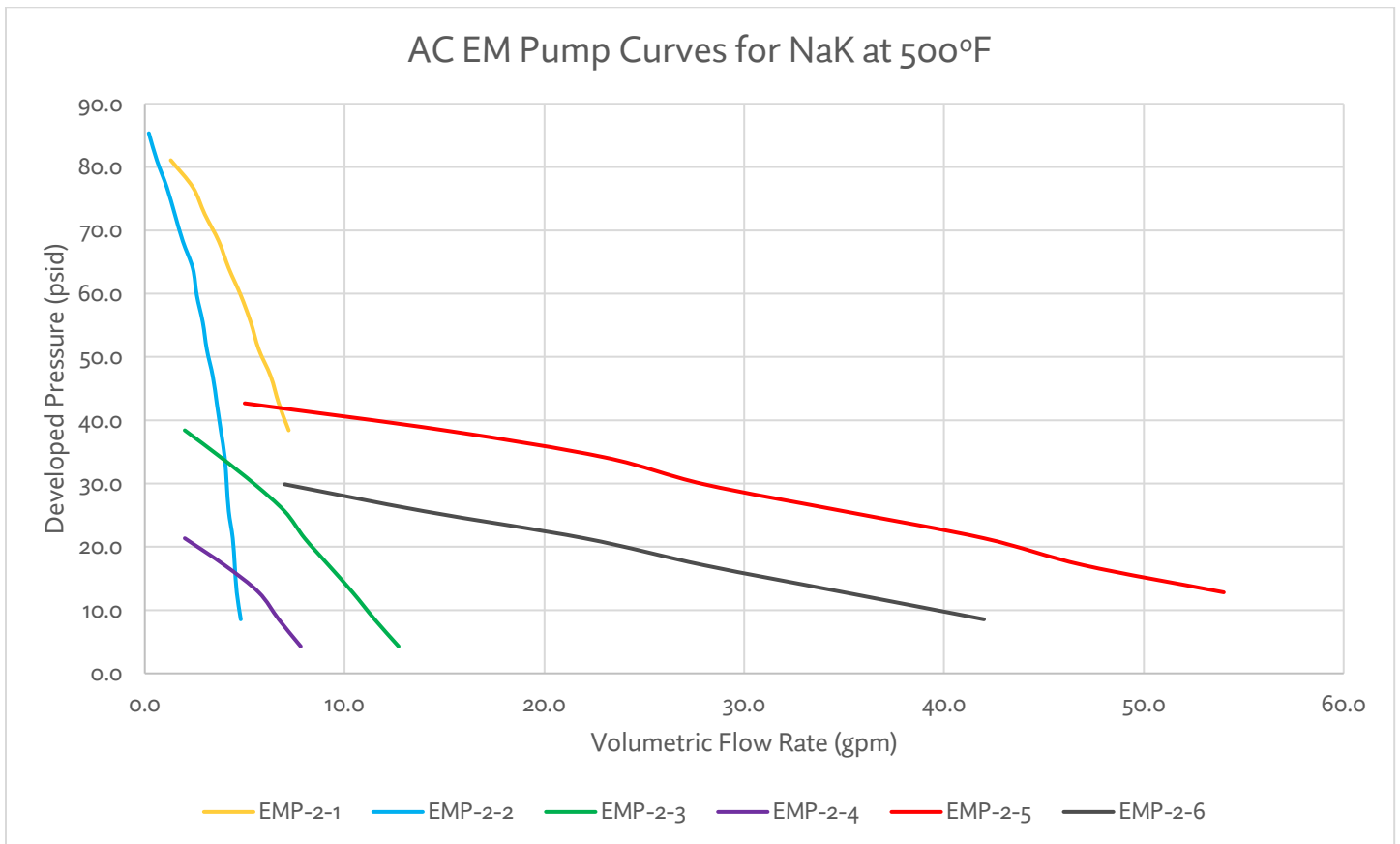

| Maximum Internal Pressure for EM Pumps in PSI (kg/cm <sup>2</sup> ) |                          |            |                 |                 |
|---|--------------------------|------------|-----------------|-----------------|
| Maximum Service Temperature   |                          |            |                 |                 |
| EM Pump Styles  | Material of Construction | 0°F (21°C) | 1,000°F (534°C) | 1,500°F (816°C) |
| EMP-2-1 & EMP-2-2   | 316SS                    | 144 (10.1) | 118 (8.3)       | 9 (0.6)         |
|   | 304SS                    | 144 (10.1) | 105 (7.4)       | 10 (0.7)        |
| EMP-2-3 & EMP-2-4   | 316SS                    | 300 (21.1) | 245 (17.2)      | 19 (1.3)        |
|   | 304SS                    | 300 (21.1) | 219 (15.3)      | 22 (1.5)        |
| EMP-2-5 & EMP-2-6   | 316SS                    | 64 (4.5)   | 53 (3.7)        | 4 (0.3)         |
|   | 304SS                    | 64 (4.5)   | 47 (3.3)        | 4 (0.3)         |

# EM Pump Specifications

| EM Pump Style | Cage Dimensions (in) | Flow Tube OD (in) | Crated Weight (lb) |
|---------------|----------------------|-------------------|--------------------|
| EMP-2-1       | 18 x 18 x 15         | 0.375             | 265                |
| EMP-2-2       | 18 x 18 x 15         | 0.375             | 265                |
| EMP-2-3       | 15 x 17 x 12         | 0.5               | 150                |
| EMP-2-4       | 15 x 17 x 12         | 0.5               | 150                |
| EMP-2-5       | 22 x 20 x 22         | 1                 | 360                |
| EMP-2-6       | 22 x 20 x 22         | 1                 | 360                |
| EMP-2-7       | 29 x 27 x 28         | 1.5               | 1550               |
| EMP-2-8       | 29 x 27 x 28         | 1.5               | 1550               |

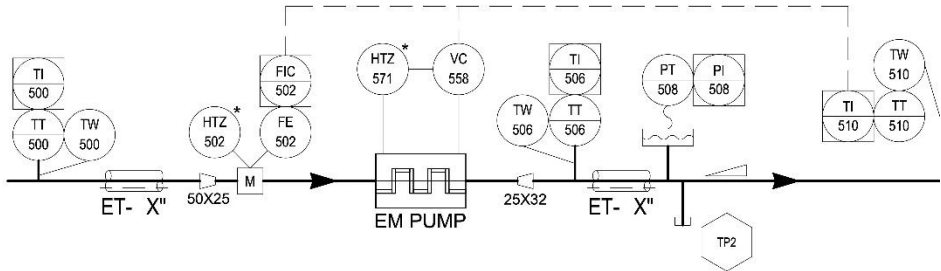

**TESTING AND CALIBRATION**

CEI has developed a dedicated and proprietary system for the testing and calibration of a variety of alkali-metal-containing equipment (see photo to the right).



## **PUMP PLACEMENT CONCERNS**

Important factors which determine where the pump should be placed in a system are below:

1. The pump must be located in such a position that it will be flooded before and during operation to prevent the high secondary armature current from overheating the pump tube. An inlet pressure at the suction end of the pump of a least two feet of liquid metal above the vapor pressure should be maintained.
2. Piping stress due to thermal expansion and contraction of the system must not place a strain on the pump in such a manner as to rupture or cause permanent distortion of the pumping section. The pump is modeled in the run as a straight piece of tube with one vertical hanger at the pump frame support.
3. The maximum rated operating temperature of the pump must not be exceeded. Ambient temperature should be maintained below 150 °F. For maximum life, forced air cooling should be supplied on all pumps which will handle fluid at temperatures above 1,400 °F continuously. An open construction is used on the pump to permit natural circulation of air for cooling.

All CEI AC conduction EM pumps are supplied with special tubular electrical heating elements for preheating purposes when pumping a material which is solid at room temperature. An applied voltage of 220 volts will provide 250 watts to the EMP-2-1, EMP-2-2, EMP-2-3 and EMP-2-4 pumps and 375 watts to the EMP-2-5 and EMP-2-6 pumps. The heater should be used only for preheating and should be turned off when the pump is operating.

If the cover gas or liquid metal vapor is trapped in the pumping section, pumping will stop immediately; and the secondary current will cause rapid heating of the pump tube. To prevent damage, a relay should be provided which will shut off power to the pump when the flow drops below a preset value.

## **INSTALLATION**

Pump installation is quite simple, whether it is to be used in a continuous loop or in an open system. The pump is supplied with flush tube ends for welding or compression fittings to connecting piping. An eye hook or hanger is provided from which the pump can be hung. The pumps are too heavy to be supported by the connecting piping. The pumps can be supported from the bottom, however provisions must be made to maintain air circulation through the pump cage. For operation over 1,200°F (650°C), a cooling via fan or compressed air may be required.

## **ALKALI OXIDE IMPACTS**

Dissolved alkali oxides in liquid metals have no effect on pump performance. However, precipitation and subsequent plugging in the flow system can produce restrictions and pressure drop – which will impact the flow rate. CEI also manufactures systems for the removal of alkali oxides and other impurities from alkali metal loops.



## ABOUT US

Creative Engineers, Inc. (CEI) is a unique and innovative alkali metal engineering company with the capability to design, build, and operate research and pilot-scale systems to meet customer needs. Each of our alkali metal expert engineers has from 5 to 30 years of experience.

The rapid results obtainable from CEI's dedicated resources often accelerate project schedules as opposed to performing the work in-house, where the researcher's efforts are often allocated among multiple projects.

We also work with other liquid metals, such as lead, antimony, bismuth, etc. and their alloys.

Contact us today at (717) 235-5469 to find out more information about our alkali metal experience.

**Electromagnetic Pumps** (or EM Pumps) are specifically designed for use with liquid metals at temperatures up to 1,500°F (816°C).

They have no moving parts and no seals and are therefore ideal for use with molten metals – including alkali metals such as NaK, sodium, and lithium.

For information on other EM pumps, please refer to our DC EM Pumps (smaller units) and FLIP Pump (larger units) brochures.

# Creative Engineers, Inc.

CUSTOMER DRIVEN SOLUTIONS

New Freedom, PA | Greenville, SC

15425 Elm Drive, New Freedom PA 17349

(717) 235-5469

[www.creativeengineers.com](http://www.creativeengineers.com)

[info@creativeengineers.com](mailto:info@creativeengineers.com)