



Creative Engineers, Inc.

CUSTOMER DRIVEN SOLUTIONS
New Freedom, PA | Greenville, SC
15425 Elm Drive, New Freedom PA 17349
(717) 235-5469

www.creativeengineers.com
info@creativeengineers.com

EMFs

Electromagnetic Flow Meters

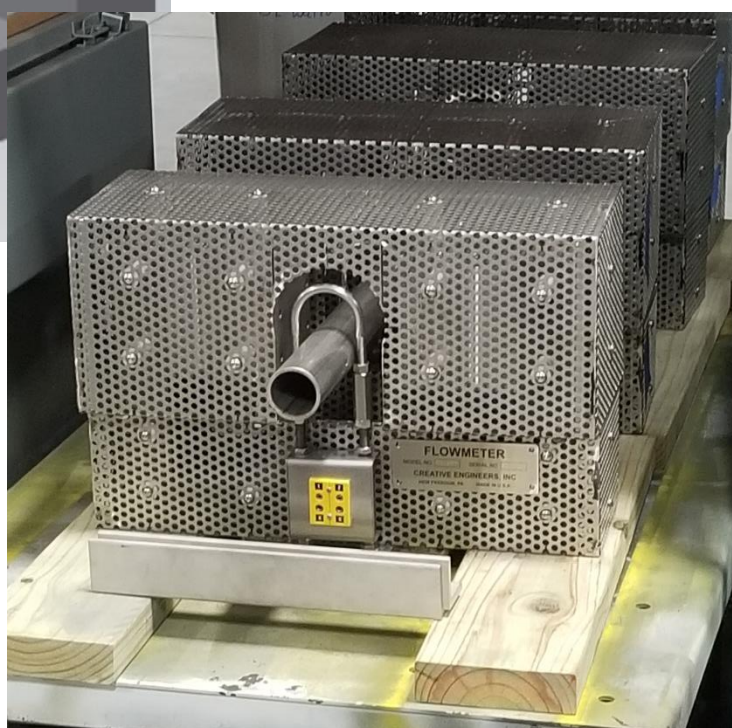
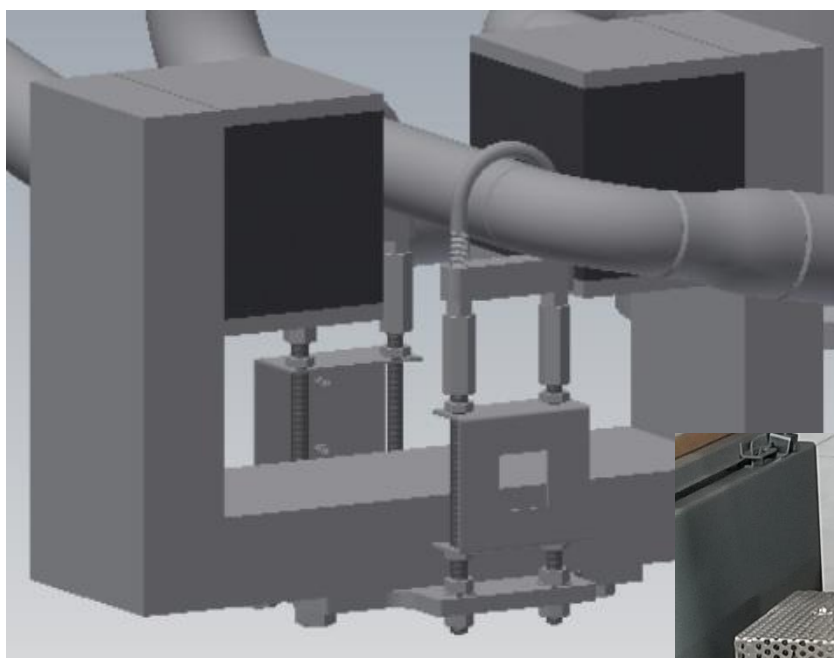

FEATURES

1. Continuous operation at liquid metal temperatures to 1,500°F/816°C.
2. No moving parts + no seals + no packing glands = no leaks!
3. Accuracy within $\pm 2\%$ of measured flow rate.
4. Straight-through flow + no internal restrictions = negligible pressure loss
5. Low maintenance – reliable for 20+ years.
6. Operable in radiation fields.
7. Proven performance since the 1950s.
8. Can be mounted in any position.

PRINCIPLE OF OPERATION

Creative Engineers, Inc.'s electromagnetic flow meters operate on the same principle as electrical generators – Faraday's Law of Magnetic Induction (see figure below). When a conductor is passed through a magnetic field an electromotive force (emf measured in volts) is created proportional to the change in flux over time. The liquid metal flowing through the tube is a conductor moving through a magnetic field created by a permanent magnet. The voltage is sensed to provide a signal proportional to velocity of flow.

An electromagnetic flow meter may be used to measure the flow of any fluid that has an electrical conductivity near or greater than that of the tube material and which will wet the tube at operating temperatures. The flow tube material must be non-magnetic and cannot be corroded by the process fluid.

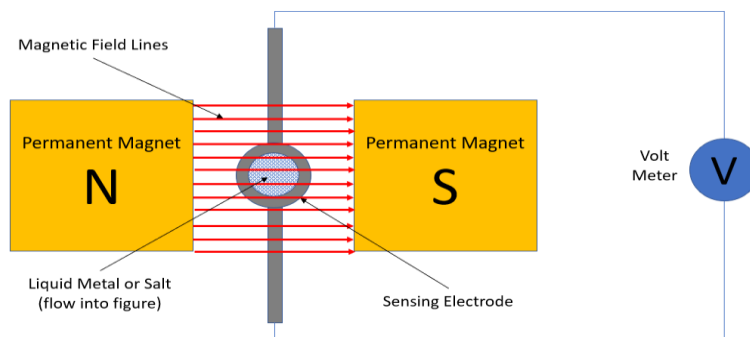

A liquid metal flowmeter is made by placing a nonmagnetic tube, such as stainless steel, between two faces of permanent magnets. The liquid metal acts as a moving conductor through the magnetic field. Electrodes are welded to the tube at right angles to the flow and the magnetic field to maximize the electromotive force (emf) sensed. The electrodes are of the same material as the tube to negate any galvanic response.

The generated voltage is proportional to the average velocity of flow. The generated voltage may be read directly by a high impedance input or may be transmitted to an amplifier by a shielded twisted pair cable. The amplifier converts the voltage signal to either an amplified voltage, typically 0-10 VDC, or a 4-20 mA DC signal that can then be used by other instrumentation. Contact Creative Engineers for amplifier and transmitter options.

EM FLOW METER SIZING AND APPLICATION OPTIONS

CEI manufactures three standard styles of electromagnetic flow meters. EFM-1 is designed for ultra-low flow rates through flow tubes as small as 1/8" OD tube. Our most commonly supplied mode, EFM-2 is designed for a range of median flow rates. EFM-3 is designed for measuring more significant flow rates. If none of CEI's standard electromagnetic flow meters fit your needs, CEI can custom design a unit to meet your qualifications.

CEI can specify the most appropriate pump for your application after receiving your process information.

EFM Style	Flow Tube Options	Air Gap Options (in)	Base Field Strengths (Gauss)	Magnet Material	Magnet Temp. Limit (°F)	Cage Dimensions (in)	Weight (lb)
EFM-1	1/8" OD Tube	0.75	14,700	N45H	302	8.5 x 8.6875 x 12.25	~20
EFM-2	1/4" OD Tube - 3/4" SCH 40 Pipe	0.5 - 6.0	8,200 - 350	N44H	248	10.75 x 11.0 x 14.0	48
EFM-3	3/4" OD Tube - 5" SCH 40 Pipe	1.0 - 10.0	3,601 - 2,872	N45SH	302	16.5 x 15.0 x 12.5	115

THERMAL INSULATION

Thermal insulation around the tube protects the magnets from the heat of the flowing liquid metal. The maximum fluid temperature varies with pipe size and air gap allowed for the magnets. CEI flow meters have been successfully operated with fluid temperatures up to 2,000°F (1,093°C). All units are designed for temperatures up to 1,500°F (816 °C) and for large mechanical loads.

A thermocouple can be provided to monitor magnet temperature. The magnets used in CEI's flow meters have been temperature-stabilized. If the permanent magnets used in CEI's flow meters exceed their Curie temperature (120°C, depending on selected magnet materials), the magnets suffer flux loss, and the flow meter will read incorrectly.

PROTECTION

The flow element can be enclosed in a protective perforated stainless steel cage (see photo on front page), have an open frame, or have protective sides.

The cages and protective sides provide mechanical protection for the magnets and electrodes while still providing for free circulation of air. They also provide protection from shock and vibration. Consideration of such factors for flow meters without such protection should be made prior to operation.

TESTING AND CALIBRATION

CEI provides a calculated operating curve specific to each flow meter's combination of model/size, liquid metal, anticipated temperature range of operation, etc.



In addition, CEI has developed a dedicated system for the testing and calibration of a variety of alkali-metal-containing equipment (see photo above). Experimentally-confirmed operating curves for each flow meter can be derived with this apparatus, if necessary.

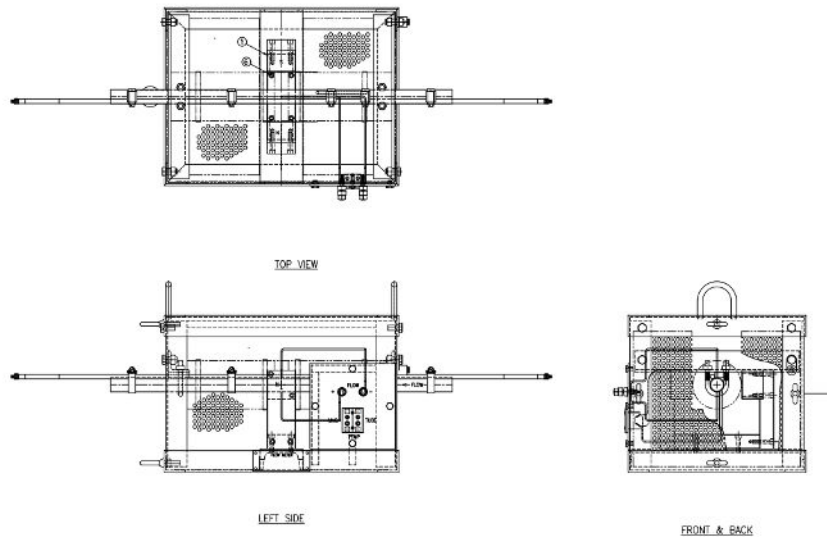

INSTALLATION

All flow meter models are designed to be attached to a hanger or platform supported. Contact Creative Engineers if a hanger is required.

An electrical resistance heater is furnished with every flow meter along the length of the flow tube to allow pre-heating prior to system filling or operation. The heater should not be operated when flow measurements are being taken.

ABOUT US

Creative Engineers, Inc. (CEI) is a unique and innovative alkali metal engineering company with the capability to design, build, and operate research and pilot-scale systems to meet customer needs. Each of our alkali metal expert engineers has from 5 to 30 years of experience.

The rapid results obtainable from CEI's dedicated resources often accelerate project schedules as opposed to performing the work in-house, where the researcher's efforts are often allocated among multiple projects.

We also work with other liquid metals, such as lead, antimony, bismuth, etc. and their alloys.

Contact us today at (717) 235-5469 to find out more information about our alkali metal experience.



Electromagnetic Flow Meters (or EMFs) are specifically designed for use with liquid metals at temperatures up to 1,500°F (816°C).

They have no moving parts and no seals and are therefore ideal for use with molten metals – including alkali metals such as NaK, sodium, and lithium.

For information on other equipment designed for use with liquid metals and alloys, please refer to our brochures.

Creative Engineers, Inc.

CUSTOMER DRIVEN SOLUTIONS

New Freedom, PA | Greenville, SC

15425 Elm Drive, New Freedom PA 17349

(717) 235-5469

www.creativeengineers.com

info@creativeengineers.com